

# mekanord marinegearbox

## 235HSC

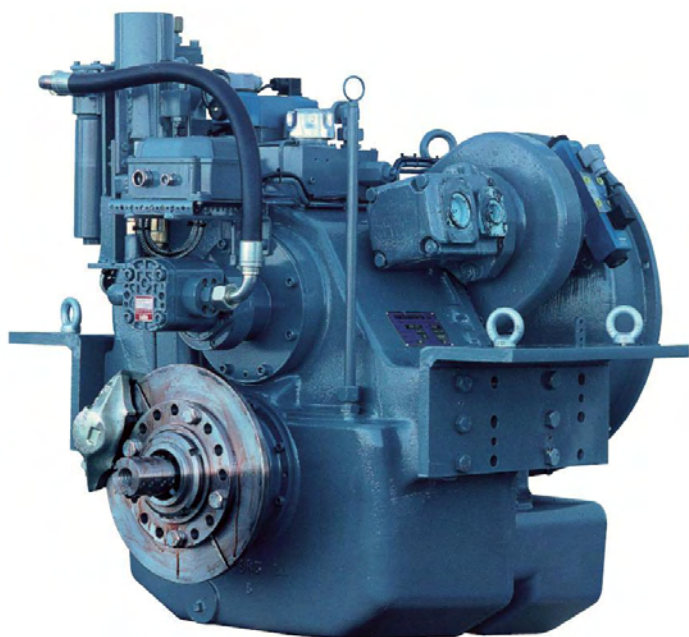
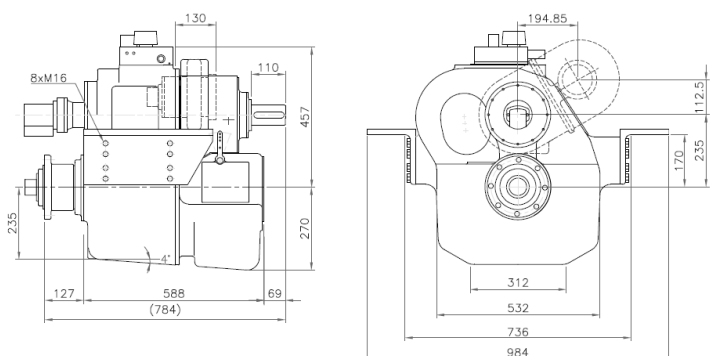

Reduction Ratio	Power Factor kW/RPM	Input Shaft Diameter mm
1,96-2,45:1	0,350	65
2,94:1	0,310	65
3,43:1	0,226	65

### Servo for CP Propeller:

Max force = 110 kN

Max stroke = 80 mm

### PTO:

PTO with SAE B-flange and 13 tooth  $7/8$ " involute inside spline

Max torque from PTO: 600 Nm

### Weight:

Approx. 400 kg plus approx. 25 kg per PTO

### Gearbox:

- Built-in servo system for CP propeller
- Compact design
- Option of 1 PTO with own hydraulic clutch
- Rigid cast iron housing
- Helical ground gearwheels in casehardened and highly alloyed steel
- Hydraulic multi-plate clutch
- Oil system with direct driven oil pump, cooler, filter, valves etc.
- Pressure lubricated spherical roller bearings
- Designed according to the rules of the classification societies
- Each gearbox is tested and approved in test bed

### Variants:

235HSC-IS with built-in intermediate shaft for counter rotating propeller

235HSC-U with U-drive

235HSC-U-IS with U-drive and intermediate shaft for counter rotating propeller