

6500D - MARINE GEARBOX

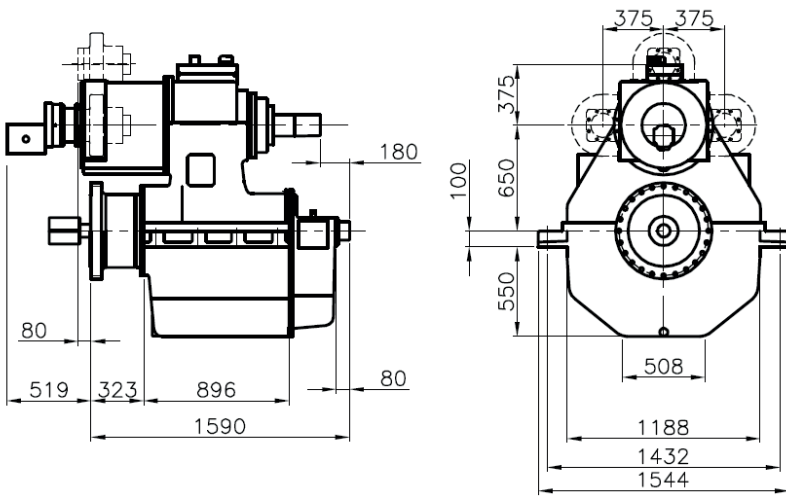

Reduction Ratio	Power Factor kW/RPM	Input Shaft Diameter mm
2,03-2,58-3,04-3,55:1	4,580	140
4,05:1	4,185	130
4,53:1	3,631	130
5,05:1	3,067	130
5,44:1	2,836	130
6,06:1	2,303	110
6,47:1	1,990	110

PTO/PTI:

PTO with SAE D-flange and 13 tooth 1 3/4" involute inside spline

Other SAE and ISO flanges and splines available

Free shaft end also available

Max torque from PTO: 2000 Nm

Max torque from PTO/PTI: 4700 Nm

Weight:

Approx. 5450 kg plus approx. 70 kg per PTO

Gearbox:

- Prepared for OD system
- Compact design
- Large economical reduction ratio
- Option of 1, 2 or 3 PTOs each with own hydraulic clutch
- Rigid cast iron housing
- Helical ground gearwheels in casehardened and highly alloyed steel
- Hydraulic multi-plate clutch
- Oil system with direct driven oil pump, cooler, filter, valves etc.
- Pressure lubricated spherical roller bearings
- Designed according to the rules of the classification societies
- Each gearbox is tested and approved in test bed

Variants:

650HS with built-in servo system for CP propeller

650HS/PTI with PTI shaft

6500D/PTI with PTI shaft

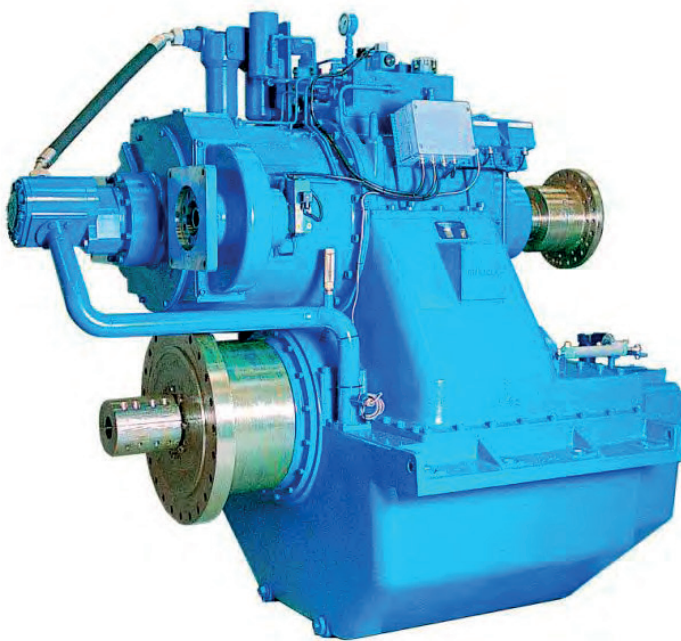

Manufacturer of **mekanord** gearboxes

For further details and additional information,
please contact our technical sales organization

sales@meproduction.dk



MEPRODUCTION
EFFICIENCY THROUGH SIMPLICITY