

5800D - MARINE GEARBOX

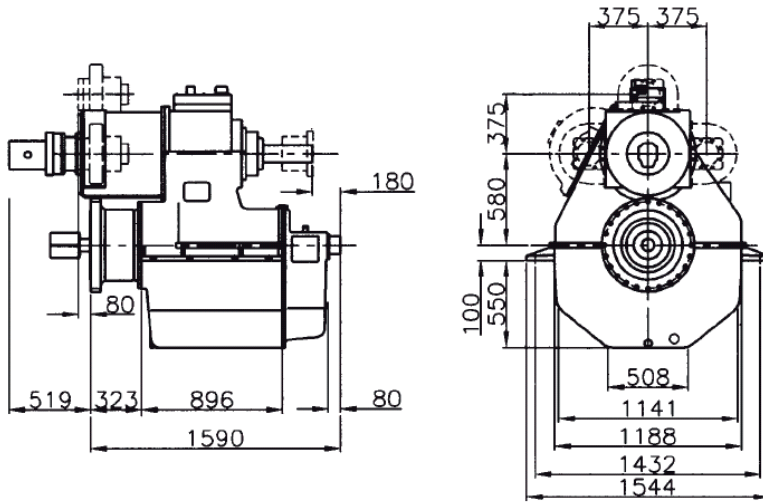

Reduction Ratio	Power Factor kW/RPM	Input Shaft Diameter mm
2,03-2,55-3,12-3,48:1	3,68	130
4,15:1	3,28	130
4,53:1	2,73	130
5,06:1	2,33	110
5,65:1	1,96	110
6,06:1	1,80	95
6,47:1	1,25	95
6,94:1	1,16	95

PTO/PTI:

PTO with SAE D-flange and 13 tooth 1 3/4" involute inside spline

Other SAE and ISO flanges and splines available

Free shaft end also available

Max torque from PTO: 2700 Nm

Max torque from PTO/PTI: 4700 Nm

Weight:

Approx. 4850 kg plus approx. 70 kg per PTO

Gearbox:

- Prepared for OD system
- Compact design
- Large economical reduction ratio
- Option of 1, 2 or 3 PTOs each with own hydraulic clutch
- Rigid cast iron housing
- Helical ground gearwheels in casehardened and highly alloyed steel
- Hydraulic multi-plate clutch
- Oil system with direct driven oil pump, cooler, filter, valves etc.
- Pressure lubricated spherical roller bearings
- Designed according to the rules of the classification societies
- Each gearbox is tested and approved in test bed

Variants:

580HS with built-in servo system for CP propeller

580HS/PTI with PTI shaft

580HS-IS with intermediate shaft for counter rotating propeller

580HS-H with horizontal offset

580OD-IS with intermediate shaft for counter rotating propeller

580OD/PTI with PTI shaft

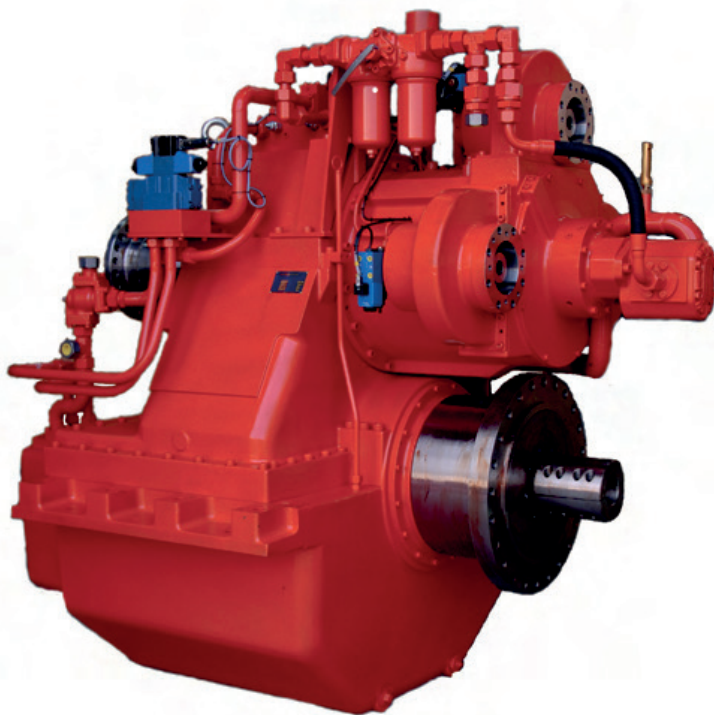

Manufacturer of **mekanord** gearboxes

For further details and additional information,
please contact our technical sales organization

sales@meproduction.dk